

**USER'S
MANUAL**

***GIGATEST*pro**

ILLKO
ILLKO

CONTENTS

1. INTRODUCTION.....	2
1.1. Safety.....	2
1.2. General description of the instrument.....	3
1.3. Standards applied.....	3
1.4. Ecology.....	3
2. DESCRIPTION OF THE INSTRUMENT	4
2.1. Instrument's case.....	4
2.2. Control panel and OLED display.....	5
2.3. Included in the set.....	6
2.4. Optional accessories.....	6
2.5. Putting the instrument into operation.....	6
3. MEASUREMENTS.....	7
3.1. Turning the instrument on and off, standby, auto power off.....	7
3.2. Notes and principles applicable to all measurements.....	7
3.3. Measurements of the particular functions.....	8
3.3.1. Voltage.....	9
3.3.2. Insulation resistance.....	10
3.3.3. Varistor surge protection devices.....	11
3.4. Other functions of the instrument.....	14
3.5. RESET of the instrument.....	14
4. MAINTENANCE	15
4.1. Batteries.....	15
4.1.1. Inserting and replacing the batteries / accumulators.....	15
4.1.2. Charging of accumulators.....	16
4.2. Cleaning.....	17
4.3. Calibration.....	17
4.4. Service.....	17
5. TECHNICAL SPECIFICATION.....	18
5.1. Functions.....	18
5.2. General data.....	19

1. INTRODUCTION

1.1. Safety



Read this User's Manual carefully and completely and follow all instructions contained therein. Otherwise using of the instrument may be dangerous for operator, for installation under test under test or for the instrument!

Explanation of the symbols on the instruments:



Protection class (double insulation)



Danger of electric shock



Warning concerning a point of danger!
Read User's Manual and observe all precautions!



The instrument meets the requirements of relevant European standards



If there is reason to believe that safe operation has become impossible, put the instrument out of operation and secure it against any unintended operation. Safe operation must be presumed to be no longer possible, if:

- The instrument does not operate properly any longer. In this case, we recommend RESET as described in the Chapter 3.6.
- The instrument, cables, connectors, plugs or accessories exhibits visible damages.
- The instrument was stored under unfavourable conditions for a long period.
- The instrument was exposed to extraordinary stress caused by transport.
- The batteries compartment cover is not properly fastened by both screws.



Observe the following safety precautions:

- Make sure that the instrument, measuring cables and all other accessories are in flawless condition, e.g. no damaged insulation, no broken cables or plugs etc.
- Do not touch conductive parts of test tips, crocodiles, test cables etc., even if only one test tip, crocodile, test cable etc. is connected to installation.
DANGER OF ELECTRIC SHOCK!
- Only a trained, skilled person, who is familiar with hazardous voltage operations, can handle the instrument.
- It is necessary to respect all safety regulations applicable to particular measurement.
- Use only standard or optional accessories supplied with the instrument by your distributor.
- Do not press any key (unless otherwise stated in this manual) when connecting the instrument to the measured installation.

- The instrument can be used only under conditions that are specified in Technical Specification, see Chapter 5.
- Do not expose the instrument to aggressive gases, vapours, liquids and dust.
- If you have transferred the unit from cold to hot environment, it can cause the condensation. We recommend a short acclimatization.
- If the device will be out of operation for a longer time, it is recommended to remove the batteries. This prevents the possibility of leakage into the device. Leakage can cause serious damage or to destroy the instrument.
- The instrument contains two fairly strong magnets. Do not leave them near the equipment and items that could be damaged by the magnetic field - such as watches, credit cards with magnetic strips, etc.
- Images in this manual are illustrative and may vary slightly from the actual state.

1.2. General description of the instrument

The GIGATESTpro is a compact instrument with patent-protected storage system of the test tips in the transport position – sharp tips are safely hidden. High contrast bright multicolour graphic OLED display ensures excellent legibility. When measured under low light conditions it is possible to illuminate the measured object by a bright white LED light positioned on the front side of the housing.

The GIGATESTpro can measure:

- insulation resistance with voltage 50 V ÷ 1000 V
- varistor surge protection devices (SPDs) 50 V ÷ 1000 V
- DC and AC voltage

1.3. Standards applied

Measurements:	EMC:	Safety:
EN 61557-1	EN 55022, class B	EN 61010-1
EN 61557-2	EN 61326-1	EN 61010-2-031
	EN 61000-4-2,3,4,5,6	

1.4. Ecology

Shipping case

It is made of cardboard and is recyclable. Please hand it to a collection point of secondary raw materials in accordance with local regulations.

Batteries

Please dispose of used batteries in the designated locations in accordance with local regulations.

The instrument



This symbol on the product, packaging or the accompanying documentation indicates that the product should not be disposed of in municipal waste. Please dispose of it in accordance with local regulations.

2. DESCRIPTION OF THE INSTRUMENT

2.1. Instrument's case

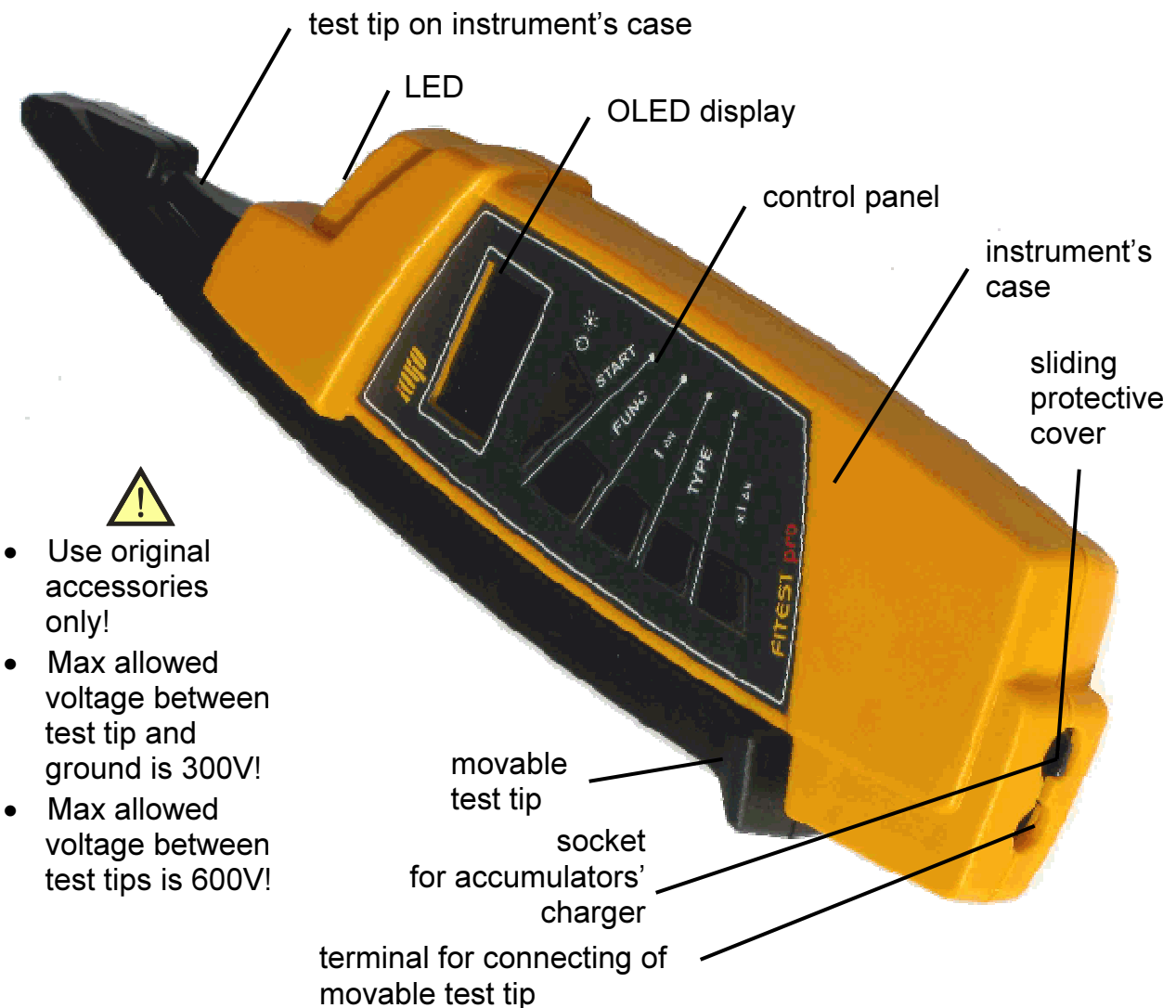

Fig. 2.1. Top side

When not in use, the instrument's body and the movable test tip can slide one into another in such a way that they form a compact unit, while the sharp end of the measuring tips are safely hidden. Against accidental ejection are both parts secured by non-contact magnetic latch.

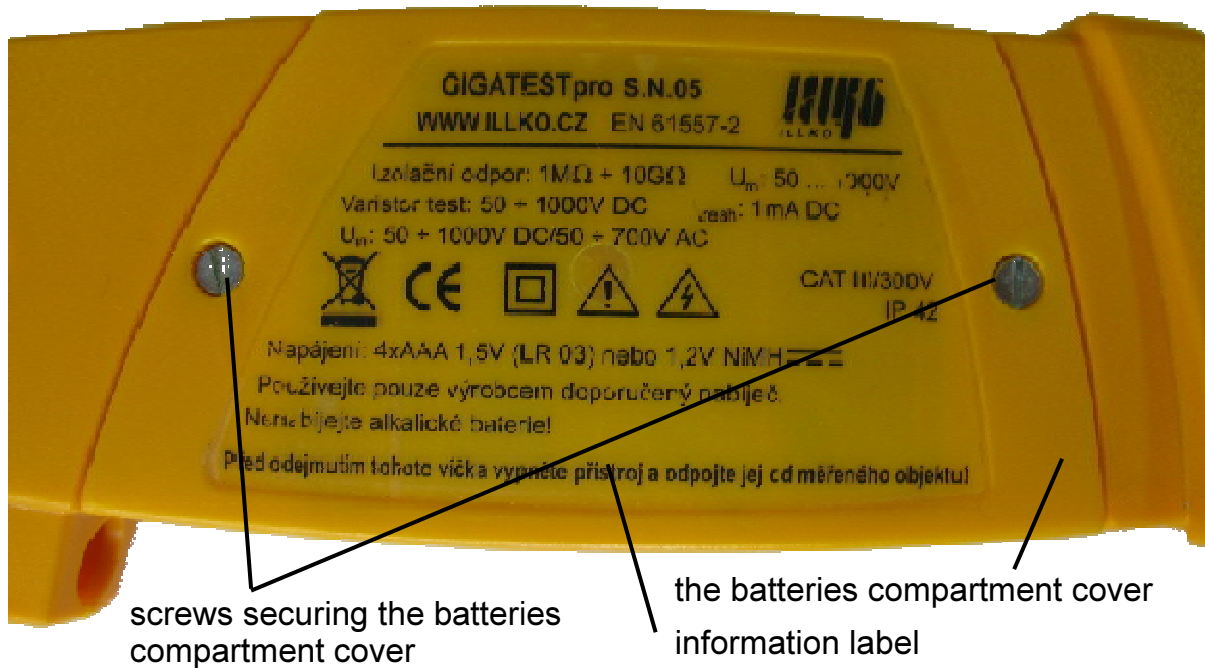

Fig. 2.2. Detail of bottom side

2.2. Control panel and OLED display

Graphical OLED display

START key starts measurement, it controls white LED (see Fig. 2.1). The key switches the instrument on and off, too.

RISO/USPD key switches the measurement of insulation resistance and SPDs.

FUNC key has no function in RISO, in USPD it enables to select another functions

Δ UTEST key to set test voltage or SPD type

∇ UTEST key to set test voltage or SPD type



Fig. 2.3. Control panel and OLED display

2.3. Included in the set

GIGATESTpro
Twisted test lead with measuring tip
Pouch
User's Manual
Calibration Certificate
Cardboard shipping case

2.4. Optional accessories

P 5050 – adapter for charging accumulators
P 5060 – set of 4 NiMH AAA accumulators
P 2011 – test lead, black, 2 m
P 3011 – test tip, black
P 4011 – crocodile clip, black

Note: optional accessories P 2011 + P 3011, respectively P 2011 + P 4011 can be connected instead of twisted test lead with measuring tip.

2.5. Putting the instrument into operation

Putting the instrument into operation consists of inserting the batteries or accumulators - the procedure is described in the Chapter 4.1. of this manual.

3. MEASUREMENTS

3.1. Turning the instrument on and off, standby, auto power off

Hold the **START** key pressed until the device turns on.

The instrument is turned off after two short pressing/releasing the **START** button, while no voltage can be applied on the test tips.

The instrument enters standby mode (reduced display brightness) after short time of inactivity (no key pressed, no voltage applied on the test tips).

From standby mode (to full display brightness), the instrument enters after pressing any button or by applying the voltage on the test tips.

Auto power off occurs when the instrument is idle (no key pressed, no voltage applied on the test tips) for about a minute.

After turning off the device can be switched on again after about 1s.

3.2. Notes and principles applicable to all measurements

- Select required parameter or function by the **RISO/USPD**, **FUNC**, Δ **U_{TEST}** and ∇ **U_{TEST}** keys. The **START** key starts measurement. All set parameters and functions remain valid until they are changed.
- If voltage applied on the test tips is > about 10 V, its value is displayed in the **U_{IN}** area and simultaneously warning symbol “!” is displayed. The **START** button does not start measurement:



Fig. 3.1 Example of voltage measurement

- If battery is low (only red part of battery indicator is displayed), then you can't start the measurement by the **START** key – after pressing it the low battery symbol is displayed for a while. Thereafter, the instrument goes into status before pressing the **START** key. Battery must be replaced / accumulators charged as described in the Chapter 4.1.



Fig. 3.2a Indication of low battery



Fig. 3.2b Low battery after the START key was pressed

- When measuring very high values of insulation resistance, put the test leads in free space, or put them to a pad made of high quality insulating material.
- Before starting the measurement by the **START** key reliably connect the test tips with the measured object. During the measurement neither early disconnect the test leads nor interrupt the connection with the measured object. Doing so may cause displaying of incorrect values.

3.3. Measurements of the particular functions



WARNING

- Make sure tested object is deenergized before measurement!
- Do not touch tested object or conductive parts of the test tips during measurement or after measurement, until tested object is discharged – RISK OF ELECTRIC SHOCK!
- Tested object can be charged to voltage up to 1050 V. Do not disconnect the test tips from tested object during or immediately after the measurement. After the measurement is finished, tested object is automatically discharged by the instrument. Voltage drop is indicated on the display simultaneously with warning symbol “!”. Disconnect the test tips when the voltage drops to a safe value, i.e. when warning symbol “!” disappears.
- When measuring the insulation resistance between conductors, all appliances must be disconnected.

3.3.1. Voltage

- Connect the instrument to object under test. Example of connection:

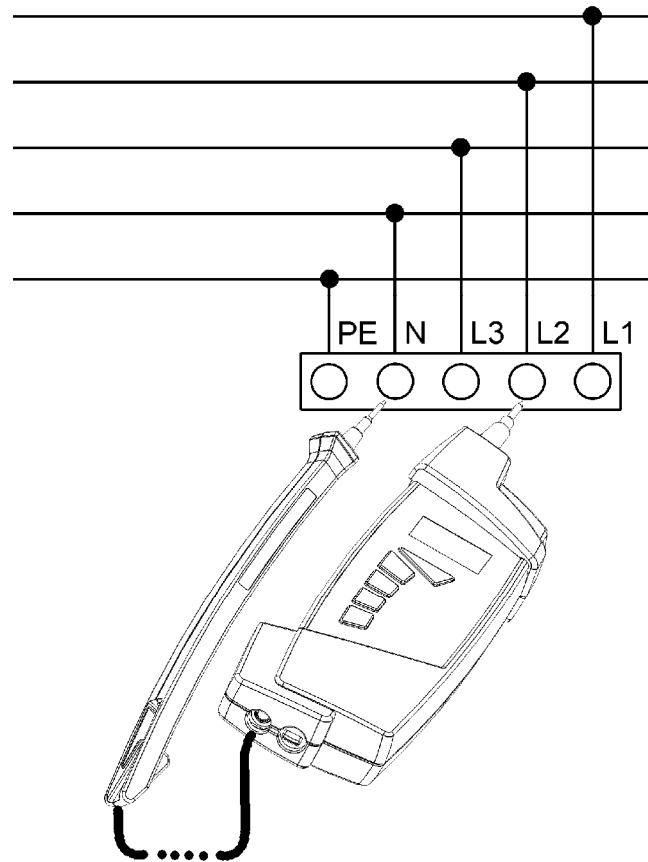

Fig. 3.3 Example of connection

- If voltage applied on the test tips is > about 10 V, its value is displayed in the UIN area. For AC voltage, symbol "~" is displayed. For DC voltage, symbol "+" is displayed if the test tip on instrument's case is connected to +, or "-" is displayed in case of the opposite polarity. Warning symbol "!" is displayed, too. The **START** button does not start measurement.



Fig. 3.4a Example of voltage measurement (RISO function)



Fig. 3.4b Example of voltage measurement (USPD function)

3.3.2. Insulation resistance

- Set RISO function by the **RISO/USPD** key:



Fig. 3.5 Example of setting for insulation resistance measurement

- By the Δ **UTEST** and ∇ **UTEST** keys select the desired nominal test voltage. By short-clicks of the Δ **UTEST** or ∇ **UTEST** key you can increase or decrease the nominal test voltage in values of 50, 100, 250, 500 and 1000 V. Value of the nominal test voltage is displayed in the **UTEST** area. To set a different nominal test voltage hold down the key Δ **UTEST** or ∇ **UTEST** until the voltage starts to rapidly increase or decrease. Step is 1 V. The exact value then set with short-clicks of appropriate button. After a few seconds after you last pressed the key Δ **UTEST** or ∇ **UTEST** the instrument goes back to a situation where short-clicks can set the nominal test voltage in the values of 50, 100, 250, 500 and 1000 V.
- Connect the instrument to object under test. Example of connection:

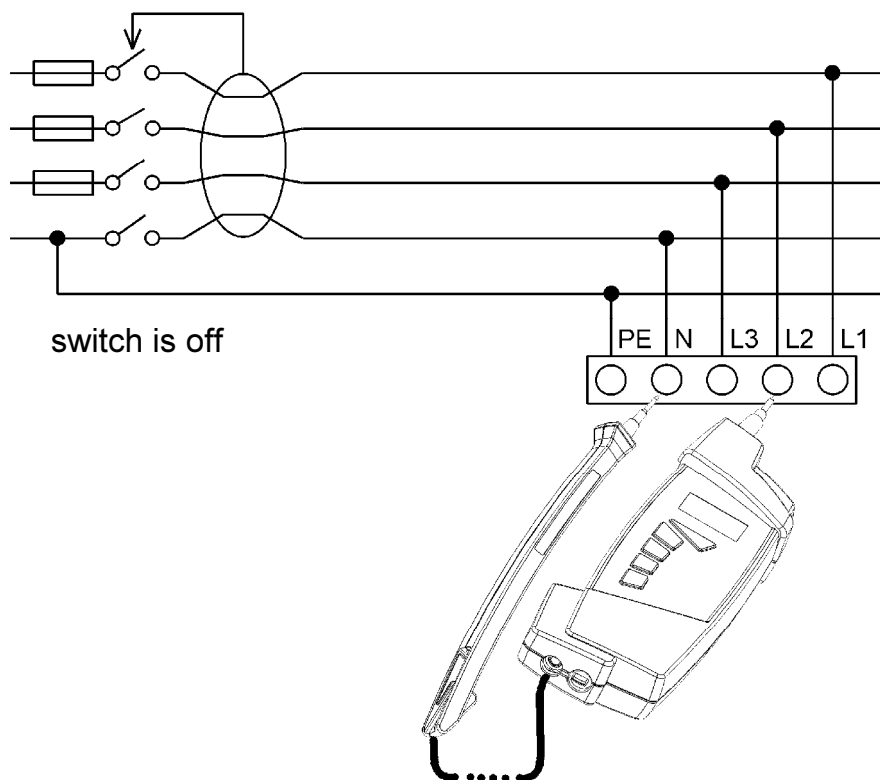

Fig. 3.6 Example of connection

Note: If voltage applied on the test tips is > about 10 V, its value is displayed. The **START** button does not start the measurement. See the Chapter 3.3.1. for details. Disconnect applied voltage - only then you can continue in measurement!

- Hold the **START** key pressed until the measurement starts. Then release the key. The increase of the test voltage (at large capacity it can last up to tens of seconds) is displayed in bar graph. The value of the test voltage is displayed in the UIN area. The measuring cycle is completed automatically. Note: If you want the measurement was made longer, it is necessary to hold the **START** key pressed during the whole measurement.
On the contrary, the automatic measuring cycle may be terminated earlier by short-clicking the START key. The measurement result in this case will not be displayed.
- Read the measured insulation resistance.
Note: Do not disconnect the instrument from tested object until warning symbol "!" disappears. Tested object is automatically discharged by the instrument and it may take at large capacity up to tens of seconds.



Fig. 3.7a Example of RISO measurement result (discharging in progress)

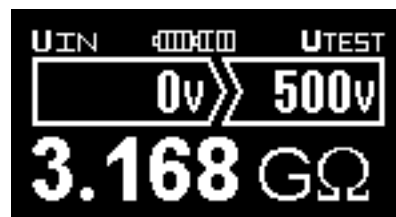

Fig. 3.7b Example of RISO measurement result (discharged)

Note: Instrument may make a hissing or whistling sound during measurement.

3.3.3. Varistor surge protection devices

In this measurement, the instrument generates a continuously increasing DC voltage in the range of about 50 V ÷ 1000 V and simultaneously measures the current through the measured varistor surge protection device (SPD). When the current flowing through the SPD reaches 1 mA, the voltage increase is stopped and the varistor voltage is displayed.



According to the function selected by the **FUNC** key the automatic evaluation of measurement result of SPD is carried out, as indicated in the table below

Notes:

If the function **USER** DCMAX is selected, then you can set by the Δ **UTEST** and ∇ **UTEST** keys the upper limit voltage used for automatic evaluation of results.

If the function **USER** DCMIN is selected, then you can set by the Δ **UTEST** and ∇ **UTEST** keys the lower limit voltage used for automatic evaluation of results.

For actual measurement / evaluation it does not matter if currently selected the **USER DCMAX** or **USER DCMIN** function.

Selected function	The symbol on the display and its meaning	
		
DC	varistor voltage has been measured	varistor voltage is out of the instrument's measuring range
USER DCMAX USER DCMIN	varistor voltage is inside the user-selected range	varistor voltage is outside the user-selected range
SPD LIST (*Note)	varistor voltage is inside the range specified by the selected type of SPD	varistor voltage is outside the range specified by the selected type of SPD

(*Note): TABLE PROTECT in some versions of firmware

If the function SPD LIST (*Note) is selected, then particular type of SPD is displayed together with the stated varistor voltage range, manufacturer and possibly with other information.

By the Δ **U**TEST and ∇ **U**TEST keys you can select the desired type of SPD.

If the description of SPD includes symbol , it means that it is a type in which care must be taken to the instructions of the manufacturer of SPD. It may be e.g. the need to measure such SPD twice under different connection, etc.

If you have any questions regarding the measurement of specific types of SPD, please contact the manufacturer of the SPD and / or look for instructions in manufacturer's technical documentation!

Information about particular types of SPDs is stored in the instrument's memory. Information were obtained from individual manufacturers of SPDs. User can not modify the information.

On the www.illko.cz can be published a list of SPDs stored in memory.

Measurement procedure:

- Set USPD function by the **RISO/USPD** key. Select desired function by the **FUNC** key (see description above). Example of displayed information:



Fig. 3.8 Example of setting of SPD function, DC function selected

- Connect the test tips to measured SPD. The actual connecting depends on the type and design of measured SPD:

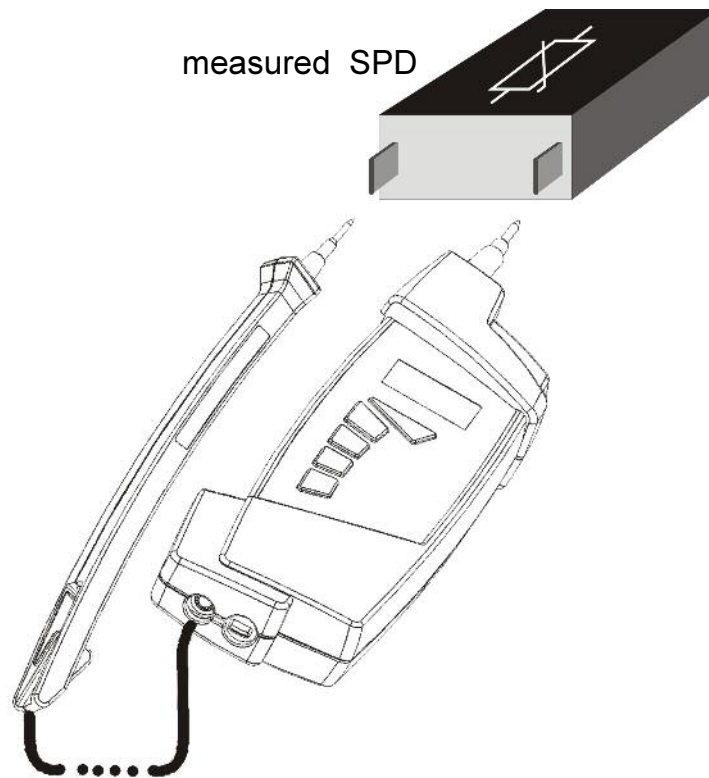

Fig. 3.9 Example of SPD connection

Note: If voltage applied on the test tips is > about 10 V, its value is displayed. The **START** button does not start the measurement. See the Chapter 3.3.1. for details. Disconnect applied voltage - only then you can continue in measurement!

- Hold the **START** key pressed until the measurement starts. Then release the key. The increase of the test current is displayed in bar graph. The value of the test voltage is displayed in the UIN area. The measuring cycle is completed automatically..
- Read the measured insulation resistance.
Note: Do not disconnect the instrument from tested object until warning symbol “!” disappears. Tested object is automatically discharged by the instrument and it may take at large capacity up to tens of seconds.



Fig. 3.10a Example of USPD measurement result (discharging in progress)



Fig. 3.10b Another example of USPD measurement result (discharged)

Notes:

- Before measurement, disconnect the SPD from the installation.
- It is strongly recommended to know in detail circuit diagram of the measured SPD. Some might have a built-in RFI filter, indicators, etc., which could misrepresent the measurement results, or even prevent the measurement.
- Instrument may make a hissing or whistling sound during measurement.

3.4. Other functions of the instrument

How to select language and to display firmware version

The instrument has to be turned off and both test tips disconnected from any circuit!

Press the **RISO/USPD** key and keep it pressed, then turn the instrument on. Firmware version (e.g. v1.0.1 and possibly additional service information) is displayed. Language selection menu is displayed, too. Release both keys. Then press the appropriate key to select the appropriate language:



Fig. 3.11 Example of language selection menu

After selecting the language the instrument enters the normal operating mode.

Illumination of measurement point with white LED

LED can be switched on/off by briefly pressing and releasing the **START** key.

Note: The test tips have to be without applied voltage!

3.5. RESET of the instrument

If the instrument does not work correctly as described in this manual, we recommend RESET:

The instrument has to be turned off and both test tips disconnected from any circuit! If you turn the instrument on and it will not restore its proper function, then remove batteries – the procedure is described in the Chapter 4.1., wait at least 10 s and insert set of new batteries. If proper function will not be restored, then remove batteries again – the procedure is described in the Chapter 4.1., put the instrument out of operation and secure it against any unintended operation. Contact service.

4. MAINTENANCE

4.1. Batteries



Dangerous voltage in batteries compartment!



Disconnect both test tips from tested object and turn off the instrument before removing the batteries compartment cover or before connecting jack to the socket for accumulator charger!



The instrument must not be put into operation without the batteries compartment cover properly fastened by both screws!

The instrument uses four AAA either alkaline cells or NiCD/NiMH accumulators. The batteries/accumulators are continuously monitored, see description in the Chapter 3.2. If batteries/accumulators are low, it must be replaced/charged.

4.1.1. Inserting and replacing the batteries / accumulators

Batteries/accumulators are inserted into the device by unscrewing two screws and removing the batteries compartment cover, see Fig. 2.2. Then remove old batteries/accumulators and insert new ones. Observe correct polarity:



Fig. 4.1 Correct batteries/accumulators polarity

Always replace all four batteries/accumulators. Use only high-quality types. Then put the batteries compartment cover back and secure it with two screws.

4.1.2. Charging of accumulators



For charging of accumulators use only adapter supplied as optional accessories!

Accumulators are charged as soon as the adapter is connected to mains and to socket for accumulators charger (see Fig. 2.1). If accumulators are fully discharged, the charging takes about 6 hours (applies to batteries with a capacity of 800 mAh). Prolonged charging is not a problem, however, do not charge accumulators for more than 12 hours.

Notes:

- Do not charge alkaline cells – it may lead to explosion, leakage, etc. This can cause serious damage or destruction of instrument.
- During charging of new accumulators or ones that were unused for a longer period (few months) unpredictable chemical processes may arise. As a result, the instrument operation time can be significantly reduced. In this case, we recommend several charge (with optional charger) / discharge (normal use of the instruments) cycles.
Another way is to use a stand-alone intelligent charger which discharge / charge each cell individually. The discharge / charge cycle is automatically executed, see instruction manual for the charger used.
After the procedure, the capacity of the accumulators should return to normal. The above described cycle in stand-alone intelligent charger is recommended every few months to make.
- If after several cycles of the above described discharge / charge capacity of the accumulators does not return to normal, this may be due to the fact that the one or more accumulators are degraded - whereas, the built-in accumulator charger charges all cells connected in series at the same time, and even one bad (or just different) cell negatively affects the entire accumulator pack.
It may result in uneven charging of cells, excessive heating of the cell(s) during charging etc.
In this case, we recommend that a faulty cell is identified with an intelligent stand-alone charger, or at least comparing the voltage of each cell and then a faulty cell replace with a new one.
- The above-described effects can not be confused with a normal reduction in accumulators' capacity over time. All accumulators with a growing number of charge / discharge cycles gradually loose capacity. This is normal, depending on accumulator type, the number and parameters of the discharge / charge cycles.

4.2. Cleaning



Disconnect both test tips from tested object and turn off the instrument before cleaning!

Wait until the instrument becomes totally dry before using it!

Use soft cloth, slightly moistened with lukewarm soap water for plastic case cleaning. Do not spill cleaning liquid over the instrument!

Do not use cleaning liquids based on petrol, hydrocarbons etc.!

4.3. Calibration

Measuring instruments should be regularly calibrated. We recommend interval of calibration 1 year. Furthermore we recommend carrying out calibration after each repair. Contact your local distributor for further information.

4.4. Service

Manufacturer, service:



ILLKO, s.r.o.
Masarykova 2226
678 01 Blansko
Czech Republic

tel./fax: +420 516 417 355
e-mail: illko@illko.cz
<http://www.illko.cz>

Unauthorized persons are not allowed to open the instrument.
There are no replaceable components inside the instrument, except batteries, refer to the Chapter 4.1.

5. TECHNICAL SPECIFICATION

5.1. Functions

Insulation resistance RISO

Operating range of use @ EN 61557-2: 0,100 MΩ ÷ Rmax*

Measuring range	Resolution	Reference error	Operating error
0,100 MΩ ÷ 9,999 MΩ	0,001 MΩ	±(2 % of R + 10 D)	±(3 % of R + 20 D)
10,00 MΩ ÷ 99,99 MΩ	0,01 MΩ	±(2 % of R + 10 D)	±(3 % of R + 20 D)
100,0 MΩ ÷ 999,9 MΩ	0,1 MΩ	±(2 % of R + 10 D)	±(3 % of R + 20 D)
1,000 GΩ ÷ Rmax*	0,001 GΩ	±(4 % of R + 15 D)	±(5 % of R + 25 D)

* Value of Rmax depends on the nominal test voltage:

Nominal test voltage 50 V ÷ 99 V Rmax = 1,999 GΩ

Nominal test voltage 100 V ÷ 249V Rmax = 3,999 GΩ

Nominal test voltage 250 ÷ 1000 V Rmax = 9,999 GΩ

Nominal test voltage Un: 50 V ÷ 1000 V, step 1 V

Open-circuit voltage: (-0% / + 10%) of the Un

Nominal test current: ≥ 1 mA (Utest > Un)

Short-circuit current: < 3 mA

Automatic discharge of tested object: yes

Number of measurements about 250 (with new alkaline cells)

Varistor surge protection devices USPD

Measuring range (V)	Resolution (V)	Reference error	Operating error
40 ÷ 1050	1	±(2 % of R + 2 D)	±(3 % of R + 3 D)

Measuring principle: Increasing DC voltage and simultaneously measures the current through the SPD.

DC and AC voltage (frequency range 45 ÷ 65 Hz)

Measuring range (V)	Resolution (V)	Reference error	Operating error
0 ÷ 600	1	±(2 % of R + 2 D)	±(3 % of R + 3 D)

Notes to the parameters stated in chapter 5.1:

a) Measured AC values are TRMS.

b) R... Reading, D... Digit.

5.2. General data

Power supply	4x AAA alkaline battery 1,5 V or NiMH accumulator 1,2 V
Over voltage class	CAT III / 300V or CAT II / 600 V
Pollution degree	2
Protective class	II (double insulation)
Degree of protection	IP 43
Dimensions	about 260x70x40 mm
Weight including batteries and movable test tip	about 0,36 kg
Reference conditions	ambient temperature $(23 \pm 2) ^\circ\text{C}$ relative humidity $40 \div 60 \%$ (noncondensing) instrument's position arbitrary
Operating conditions	ambient temperature $0 \div 40 ^\circ\text{C}$ relative humidity max. 85 % (noncondensing) instrument's position arbitrary
Storage conditions	ambient temperature $-10 \div +70 ^\circ\text{C}$ relative humidity max. 90 % $(-10 \div 40) ^\circ\text{C}$ (noncondensing) max. 80 % $(40 \div 70) ^\circ\text{C}$ instrument's position arbitrary

Copyright © 2010, ILLKO, s.r.o.

Copying or any other way of duplication of this User's Manual or its parts is allowed with antecedent written permission of ILLKO, s.r.o. only!